

Please cite this paper as:

OECD (1998-04-07), "Internet Voice Telephony Developments", *OECD Digital Economy Papers*, No. 35, OECD Publishing, Paris.
<http://dx.doi.org/10.1787/236747051303>



OECD Digital Economy Papers No. 35

Internet Voice Telephony Developments

OECD

Unclassified

DSTI/ICCP/TISP(97)3/FINAL



PARIS

Organisation de Coopération et de Développement Economiques
Organisation for Economic Co-operation and Development

OLIS : 03-Apr-1998
Dist. : 07-Apr-1998

Or. Eng.

DIRECTORATE FOR SCIENCE, TECHNOLOGY AND INDUSTRY
COMMITTEE FOR INFORMATION, COMPUTER AND COMMUNICATIONS POLICY

Working Party on Telecommunication and Information Services Policies

INTERNET VOICE TELEPHONY DEVELOPMENTS

63935

Document complet disponible sur OLIS dans son format d'origine
Complete document available on OLIS in its original format

DSTI/ICCP/TISP(97)3/FINAL
Unclassified

Or. Eng.

Copyright OECD, 1998

Applications for permission to reproduce or translate all or part of this material should be made to:

Head of Publications Services, OECD, 2 rue André-Pascal, 75775 Paris Cedex 16, France

TABLE OF CONTENTS

MAIN POINTS.....	4
1. SCOPE OF THE REPORT.....	6
2. DESCRIPTION OF SERVICE AND NETWORK.....	7
Service description.....	7
Network description.....	8
Internet traffic and the PSTN.....	9
Interoperability and standards.....	11
Intranet telephony.....	11
3. REGULATORY SITUATION IN OECD COUNTRIES.....	13
4. INTERNET TELEPHONY AND TARIFFS.....	15
Tariff comparison between Internet telephony and PSTN.....	15
VAT issues.....	16
5. MARKET AND POLICY ASPECTS.....	18
Market players.....	18
Market potential.....	18
Impact on the service market.....	19
Impact on telephony revenues.....	19
Impact on tariff structures.....	20
Impact on level of accounting rates and total settlements.....	21
Examples of changes in international payments.....	21
Applicability of telecommunication legislation.....	22
6. POLICY CONSEQUENCES.....	24
GLOSSARY.....	25

MAIN POINTS

Internet telephony is a voice service over the Internet. It is different from the present telephony service which is transported over the circuit switched public telephone network because Internet telephony is transported using Internet protocols over packet switched networks. Internet telephony calls can be set up between personal computers and also from a computer to a normal telephone. In the near future the service will also be available from a telephone to another telephone. The potential of Internet telephony is stimulating software application developers to integrate voice, data, audio and video applications.

During 1995 and 1996 Internet telephony was initiated by small players in the computer and communication market, but has recently stimulated the interest from the larger ones. Competition with traditional telephony will be mainly through pricing and by new service features such as voice video combinations. At present the quality of Internet telephony is lower than existing telephony services over the Public Switched Telephone Network (PSTN). The Internet network providers foresee a strong growth in traffic but need to invest to improve quality, operability, reliability, security and network management of the Internet, in order to achieve the same level of quality as the PSTN. Also Internet service providers foresee a growth in the number of subscribers when they take the role of telecommunication service provider. The availability of standards for Internet telephony and particularly for the coding and decoding equipment is highly important in order to offer interoperability.

The announced international call charges for Internet telephony are low compared with international call charges over the PSTN, which will further stimulate tariff re-balancing, in a similar way to call-back services. This is in line with a widespread public policy aim to lower accounting rates. Internet telephony uses the packet switched network which does not have an accounting rate system. It is assumed that competitive pressure from international internet telephony will tend to push accounting rates on the PSTN downwards. International internet telephony will also impact on the settlement payments because it will replace calls using the PSTN and may also stimulate international calls on either network.

Internet use in total is leading to much longer sessions than the average voice telephony calls. This is increasing demand for capacity in the local loop, particularly in those countries with unmeasured local calls and flat rate Internet access provider charges, as there is no price incentive to log out. Interactive communication services over the Internet will further stimulate the use and consequently demands placed on local loops. This interactive traffic is different from web surfing and will probably lower the average session time. However lower prices will also influence communication behaviour and may result in more and longer long-distance (international) calls. Telecommunication operators invest in network capacity to handle the growth in traffic through all parts of the networks. In the local loop a much higher demand for capacity and the changed type of traffic may require a higher level of investment in order to continue the same availability of network for guaranteed services. In countries with timed local calls or timed Internet Service Provider (ISP) charges, the relation between growth of traffic and the increase in capacity is probably more direct than in countries without timed local calls.

Voice services over packet switched networks, such as Internet telephony and related video services, illustrate the convergence in telecommunication. The liberalisation of the telecommunication market opens the possibilities for combining existing service and network technologies and Internet telephony is an example of the integration of the computer and telecommunication business. The use of alternative infrastructures also injects new service features.

The technological development surrounding this integration is very rapid and occurring much faster than change in regulations. The use of alternative network infrastructures and the fact that new companies often start by exploring new possibilities, stimulates competition in the communication market. This is in line with most existing telecommunication policies. Regulation should be independent from the technology in order to allow growth in the communication market through exploiting new service and network combinations. The use of alternative networks can be expected to enhance the diversity of service supply.

To most customers it is irrelevant whether voice communication is handled through a packet switched network or circuit switched network, as long as the price is reasonable for the quality of service received. The choice of technologies is one for operators to make based on the most efficient network solution for service provision.

Some OECD countries do not treat Internet telephony differently from existing voice services. In a number of countries Internet telephony is treated in a more liberal way than voice over PSTN, probably because the deregulation of voice service provision is at an advanced stage and because the service has a small impact at the moment. In a few countries Internet telephony is legally not allowed. However developments in Internet telephony are hard to stop through country specific regulation because of the global characteristic of Internet.

Some countries charge VAT on communication services. As telecommunication services provided over the Internet can be provided from any location in the world, the telecommunication business can be based in countries with favourable tax obligations. This taxation issue is difficult to resolve and needs to be reviewed by governments that impose consumption taxes.

1. SCOPE OF THE REPORT

Internet telephony developments have obtained much attention in the media since about a year, however the scope of this document is not limited to telephony nor is it limited to Internet. Internet telephony typically functions as an example of a combination of services and networks that until now were not legally possible or not attractive to the telecommunication providers as a service to offer. Opening of a legally closed market has resulted in markets abandoning the fixed relations between services and dedicated networks. Therefore instead of 'telephony' one may read 'voice services' or even all kind of services that are received via circuit switched networks. Internet also includes 'intranet' services. Voice services over intranets may grow even faster than over Internet, as many companies already work with data services and have connections to packet-switched networks.

2. DESCRIPTION OF SERVICE AND NETWORK

Service description

Internet telephony is a voice service over the Internet. Until the end of 1996 Internet telephony required in most cases a computer, equipped with microphone and speakers, special software for the telephony service at both sides, a network connection (digital line or modem) and a subscription to Internet via an Internet Service Provider (ISP). With such requirements Internet telephony could only be used by a limited number of people. At the end of 1996, Net2Phone announced they would introduce an Internet telephony service which allowed calls to be initiated and terminated on normal telephones¹.

To make an Internet telephony call from a normal telephone terminal the user calls a local access number (or an 800 or 900 number), which connects the call to an incoming server. The user will be asked to enter their account number and the destination telephone number. Next the call is routed from the Public Switched Telephone Network (PSTN) to the Internet packet switched network. The Internet carries the call to a terminating server, located as close as possible to the destination telephone. The terminating server switches the call back into the local telephone network which completes the call. The costs of the call consist of the costs for access to the Internet, the transmission and the costs for terminating the call in the PSTN. Apart from that, the user pays the local network operator for the call to the Internet telephony provider.

Voice service over a packet switched network, like Internet, has been possible for some time, but the accessibility was low due to hardware and software requirements. Voice communication over networks other than PSTN is not allowed by law in a number of countries, but will soon become legally possible after abolition of rules that strictly define combinations of networks and services.

New service opportunities via the Internet, such as combinations with video and audio are very important and could give Internet telephony a competitive advantage. The traditional telecommunication market will be influenced by the new players that will compete with the PTOs in both networks and services. Examples of new players are the ISPs, Internet equipment manufacturers and software developers for world wide web applications. The Internet is also levelling the international playing field for small companies, irrespective of their location in the world.

Internet telephony may become more successful in combining voice and other applications such as voice mail, e-mail, audio and video. A number of Internet telephony software developers have recently added video capabilities to their Internet telephony software, which allows customers to make video-conference calls². Another example of an Internet service is fax over the Internet. The company Clarity Software Inc. provides a fax service for free if both sender and recipient have the company's software installed, if not the call will probably cost a local call charge³.

Network description

Traditional telephone calls are set up over circuit switched public networks. Internet telephony calls are set up over the Internet, which is a packet switched network using the Internet Protocol (IP), (Figure 1). Most residential users are connected to the Internet via the PSTN local loop, whereas a number of business users, such as private and public organisations, have a dedicated connection to the ISP and their Internet backbone.

The Internet is a service based on the Transmission Control Protocol and Internet Protocol (TCP/IP) that are implemented on packet switched networks. Generally customers are connected via the circuit switched PSTN network to the local switch, where traffic is routed to the packet switched network. The local loop communication can be passed via a digital connection, such as Integrated Services Digital Network (ISDN), or via a modem, preferably at least 28.8 kbit/s for Internet telephony. At the moment the most important user-interface for Internet telephony is a www-browser plus voice telephony software installed on the personal computer.

Figure 1. Network diagram for connection between the user's PC and the ISP

(LEX=Local EXchange)

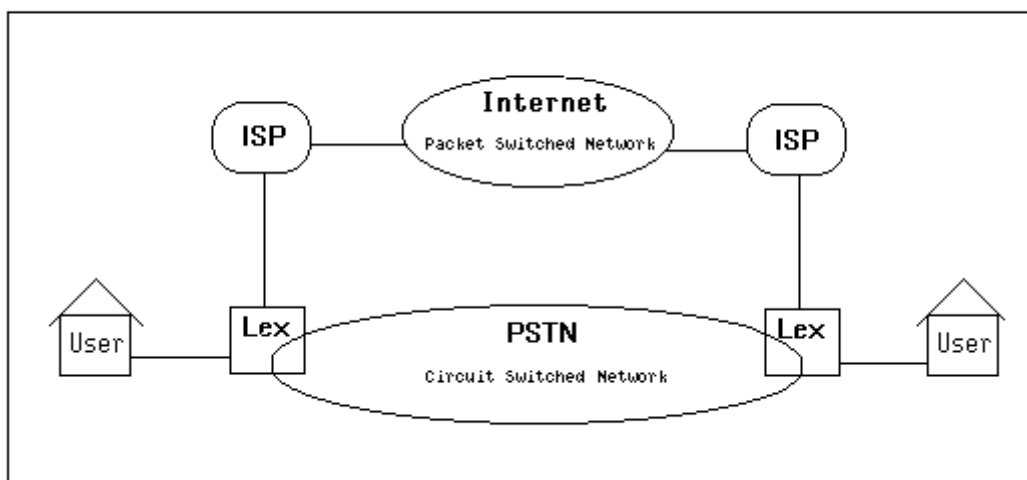

Provision of telephony services over packet switched networks has been in preparation for several years by PTOs through the investments in the development of the transmission technique Asynchronous Transfer Mode (ATM). ATM is a transport technique based on switching packets. It is a bandwidth-on-demand technology and has capabilities which allow service providers to offer various levels of quality of service. Implementation of ATM has started at the highest inter-exchange levels and will gradually be implemented in lower network hierarchy levels. End-users can be connected to ATM directly or via, for instance, high capacity Digital Subscriber Loop (xDSL technology)⁴. The combination of ATM, IP and Asymmetric Digital Subscriber Loop (ADSL) is of interest to the telecommunication

operators. For example Telia has announced it plans to use ADSL on a very broad scale, i.e. 6 million lines in the next six to seven years⁵.

As Internet telephony data is sent as a stream of packet switched Internet messages, the quality does not yet reach the same level of quality as offered via a circuit switched link, in terms of reliability, availability and security. An example of the delay over the net given by the National Laboratory for Applied Network Research (NLNR) is typically between 100 and 750 ms⁶. Vocaltec, a leading Internet telephony company, say a delay of 'typically half a second to a second' will be experienced by users. Such a delay is problematic in an interactive communication, but is far less important when communication is one way, e.g. a voice report from a reporter. With message services, including facsimile, delay is not perceived as inconvenient. The permanent available capacity of a circuit over the PSTN leads to a high quality for many services, but is not very efficient because often only a small part of the total capacity is used. As the number of Internet users is rapidly growing and usage patterns are changing, the quality of service of Internet is not stable. It may get worse before it improves and this may affect other Internet services.

Internet traffic and the PSTN

This Section briefly describes the situation of Internet traffic over the PSTN local loop. It is not specific to Internet telephony as this service only forms a relatively small part of total Internet traffic.

The PSTN is a network that is efficient to set up connection-oriented sessions, so-called circuits, but which is not always efficient to transport packets. Network and service management together take care of pre-defined level of quality, availability and reliability of the circuits, for instance via mechanisms for re-routing and congestion control.

Residential and small business customers get Internet access and other computer communication via the PSTN local access network. During an Internet session, defined as the duration a customer is logged on, packets are transported over the circuit in the PSTN local access network. Packet traffic is not constant like voice, but very fragmented over time. A typical example is when a user sends a command to download a page or document and some time later a burst of packets is transported to the user. The rest of the time both the circuit and related equipment in the switch, such as a line card, are seized but not used. Figure 2 gives an overview of the capacity of a local circuit and how it is used.

Internet sessions are normally several times longer than average telephone calls and therefore demand more circuits available at the same time in the local exchange. But the total traffic is not handled in an efficient way and therefore methods should be found to optimise the network since the type of traffic is changing. Second lines and higher bit rate protocols such as ISDN and xDSL add more capacity but do not change the principle difference between connection oriented and connection-less networks.

As the packet switched Internet service is using a switched circuit not very efficiently, a measure for PTOs would be to separate packet data from connection oriented data before the local switch. This would be in order to route the packets immediately into the packet switched network (Figure 3). PTOs should be able to handle this change as it is in their interest to keep the right quality of service for the circuit switched networks and as well to handle the extra traffic from Internet as efficiently as possible. The US Federal Communications Commission's (FCC) Network Reliability and Interoperability Council (NRIC) is studying the impact of Internet on the telephony network. It is said that until now no carrier has reported an event associated with Internet use that meets the threshold for reportable outages -- generally a network failure that deprives more than 30 000 customers of the ability to make a call for more than 30

minutes. However, rapid Internet growth represents a capacity management challenge often requiring rapid and costly equipment augmentation⁷.

Figure 2. Capacity in use for voice over a circuit compared with packet switched data communication

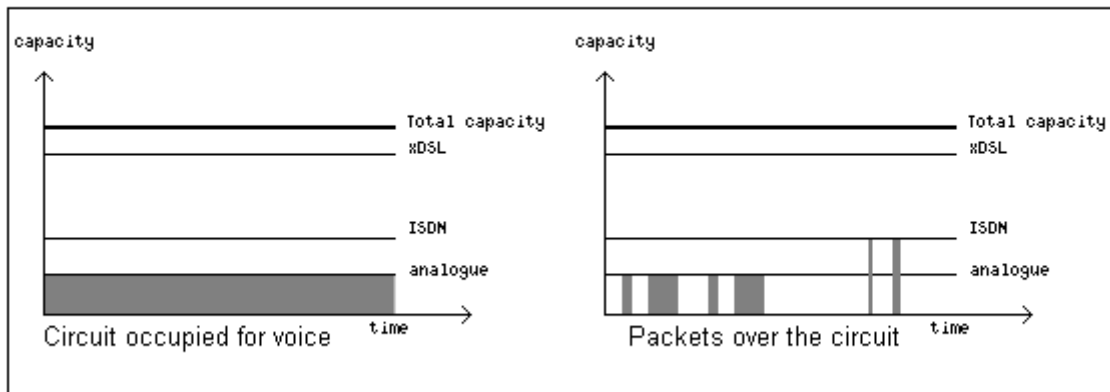
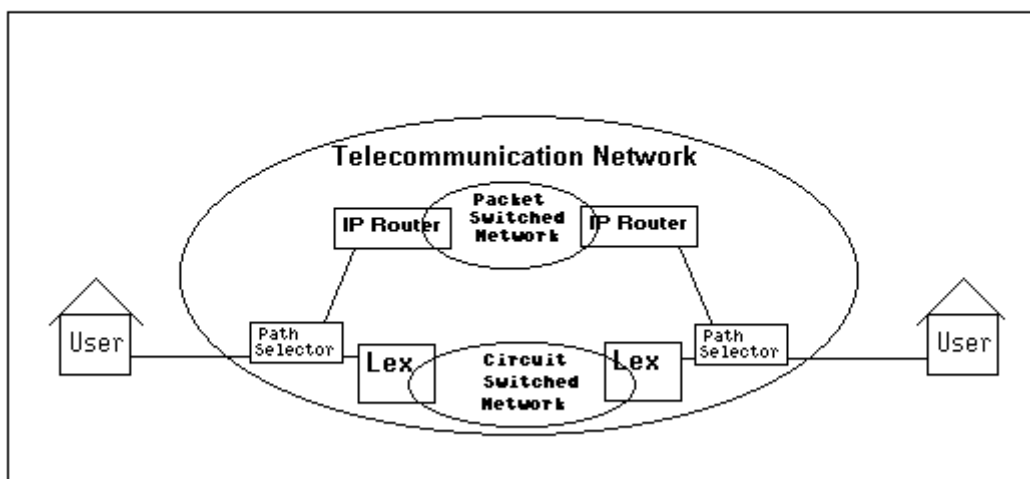

Figure 3. Network diagram that shows a selector to split traffic for the circuit and packet switched networks



Internet telephony probably represents only a small part of total Internet traffic. To get the quality of service and the availability required for a voice service, additional intelligence is needed, for instance resource reservation protocols, reserved paths for data and queuing algorithms.

Interoperability and standards

The success of Internet telephony depends very much on interoperability. The service started with voice communication between two computers, requiring both to be equipped with the same software. Since calls can now be terminated in the PSTN and other networks, the potential utilisation of the service has gone up significantly. Interoperability between the Internet telephony service and the PSTN telephony service requires interconnection agreements to get calls terminated in other networks and requires also agreement on standards to interoperate.

The ITU standard H.323 is widely accepted as the standard for voice and video over IP (Internet Protocol) and is therefore important for Internet telephony (G.723.1 as speech codec). To improve the real-time quality of Internet telephony it is important to have the new version of IP available (version 6, will probably be available by the end of 1997) and to use the Real Time Protocol (RTP) of the H.323 standard. Related are the ITU T.12x series that standardise data conferencing and defines network interfaces, a session model, data transmission facilities and some standard applications⁸.

Apart from the ITU other organisations are working on interoperability. One example is the International Multimedia Teleconferencing Consortium (IMTC). It has the mission to bring together all organisations involved in the development of multimedia teleconferencing products and services to help create and promote the adoption of industry-wide interoperability standards⁹. Other examples are the International Teleconferencing Association, the International Multimedia Association and the Internet Engineering Task Force (IETF). The IETF is the protocol engineering and development arm of the Internet and is an open international community of network designers, operators, vendors, and researchers concerned with the evolution of the Internet architecture and the smooth operation of the Internet. Membership is open to any interested individual.

Intranet telephony

For several years the integration of data services and voice services has been in place in private networks, mainly in large companies. In many cases the Private Branch eXchanges (PBX) and IP-routers are connected to the company's Local Area Networks (LAN). In a more sophisticated system both the telephones and PCs are connected to a LAN (see for example ViennaSystem¹⁰). If voice services are transported in packets over the LAN, the next step could be to route outgoing voice services, via a gateway, to the public packet switched networks. The gateway needs to be able to handle incoming voice service from both the packet switched network and the PSTN. See Figure 4.

Figure 4. **On the right side an example of how telephones, like computers, are connected via the LAN, to the IP network. On the left side the classic solution via the PBX**

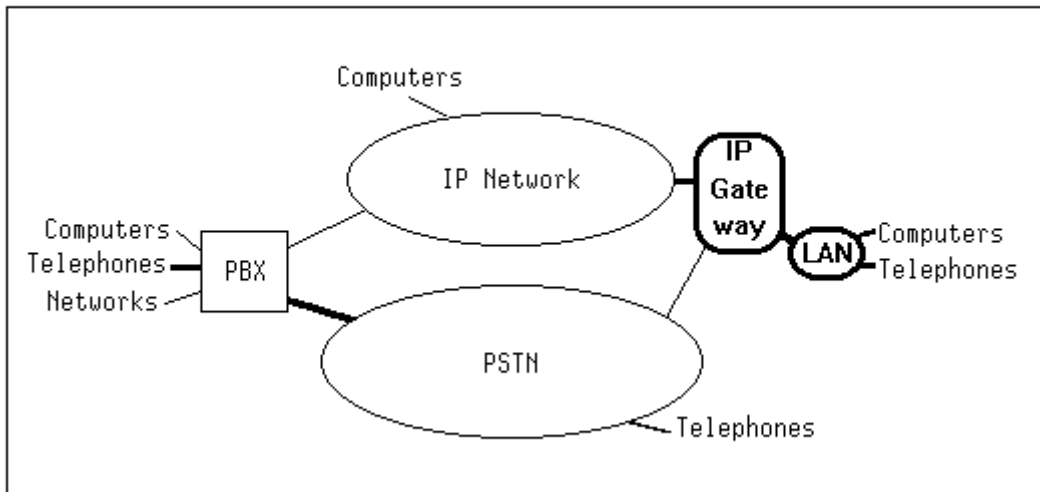

3. REGULATORY SITUATION IN OECD COUNTRIES

At the moment most OECD countries do not treat Internet telephony differently from voice over PSTN. That means that voice services may only be provided by those PTOs having a (exclusive) licence to provide voice services. However, quite a number of these countries accept voice over the Internet without formal permission although their voice market is not yet open. Reasons given by countries are the innovative character of the service/network combination and its small impact at the moment. In addition the fact that by the beginning of next year the majority of OECD communication markets will become much more liberalised makes permission for provision of Internet telephony less relevant.

A few countries do not allow any voice services over the Internet. The Czech Republic does not allow the service within the ISP licence, nor does Hungary, which treats Internet as a corporate network that may not offer an alternative to the public network. A few European OECD countries are maintaining voice services as the exclusive right of their incumbents after 1998. In some of these countries this exclusivity is interpreted as disallowing the provision of public voice services using Internet. However, owing to the global nature of the Internet, it is difficult to hinder developments in Internet telephony through national regulations. Table 1 gives an overview of regulatory requirements for Internet voice services in OECD countries.

The European Commission is seeking comments on the status of voice on the Internet under Directive 90/388/EEC. It questions whether it should propose legislation on telephone calls carried on the Internet. It said in a statement that such calls did not appear to fall under existing rules on voice telephony, which require filing for operating licenses, but needed to be studied in the light of the full liberalisation of the EU's telecommunication market in 1998¹¹. In the meantime Japan's Ministry of Post and Telecommunications decided to allow Internet telephony from August 1997.

Table 1. **Regulatory Requirements for Internet Voice Services**

Australia	Data services, such as Internet, are subject to minimal regulation (i.e. not subject to enrolment or public interest requirements). All international double ended interconnected public switched services provided by service providers are subject to enrolment procedures (e.g. provision of details on organisation and the type of service it intends to supply) with regulator and must be provided in the public interest (the onus is placed on the service provider that the service is supplied in the public interest.)
Austria	No restrictions. Not regarded as a reserved service.
Belgium	Voice telephony as defined by EU Directive 90/388 is the monopoly of Belgacom.
Canada	Not required to obtain regulatory approval for rates for providing national or international Internet telephony but they are required to make appropriate contribution payments to the local telephone network under the same rules as for PTOs. According to CRTC all voice services are treated equally, including Internet telephony. This applies only to telephony resellers that advertise their service going over the Internet
Czech Republic	Internet licences contain specification of allowed services -- Internet telephony is not permitted.
Denmark	International voice telephony services provided over the Internet are not defined and/or treated differently from international voice telephony services provided by other means.
Finland	Free regime, if voice telephony services form only a minor portion of Internet services.
France	The Internet is a network for data transmission on which some users transmit voice. Currently, there are no providers offering public vocal telephony on the Internet. If that were the case the general framework of regulation applying to vocal telephony would be applied.
Germany	No restriction.
Greece	Only liberalised telecommunication services are allowed to be provided over the Internet. OTE has a the exclusive right for voice service. Issue is under study.
Hungary	Internet - being treated like a corporate network - shall not be an alternative for national trunk or international voice traffic. Internet should not be interconnected with voice channels or access of PSTN.
Iceland	The exclusive right of voice telephony is vested in the hands of the PTO and would be treated as illegal by others.
Ireland	Voice telephony as defined in EU Law (Directive 90/387/EEC) is reserved to Telecom Eireann until 1/1/2000. Voice services (national and international) which do not constitute voice telephony are permitted.
Italy	Internet does not modify the general regulation on the provision of voice telephone services which is a monopoly.
Japan	There is no particular definition of voice telephony on the Internet and no special handling of or regulation on Internet voice telephony services. Users are free to decide what information is transmitted (e.g. data, image, voice).
Luxembourg	N/A
Mexico	No restrictions.
Netherlands	No restrictions.
New Zealand	Internet telephony services are not defined or referred to in any legislation.
Norway	Allowed among closed user groups. Provision of public voice telephony by other than the PTO is not allowed.
Portugal	Voice telephony services, both national and international, are not allowed until 1/1/2000.
Sweden	Presently not under licence restrictions.
Switzerland	Swiss PTT has monopoly rights to provide voice telephony to the public until 1/1/1998. After that no restrictions. This applies to national and international voice telephony services.
Turkey	N/A
UK	Too early in the development of technology to determine regulatory status.
US	No restrictions on the provision of voice services over the Internet.

Source: OECD, Communication Outlook 1997, Table 2.7.

4. INTERNET TELEPHONY AND TARIFFS

Tariff comparison between Internet telephony and PSTN

At the moment Internet telephony is a low priced lower quality telephone service. Consequently its main competitive advantage is the lower price of international calls compared with traditional service and call-back service. Competition with long-distance / national calls may be attractive because of the large market volume, although the price difference is less. Table 2 and Figure 5 show the price differences for a 3 minute call, for three international calls from France and one national long distance call in France. The services used in the example are the Internet telephony service from IDT¹², the call back service from AT&T¹³ and the PSTN service (peak and off-peak rate) from France Telecom¹⁴. The Internet telephony call is routed via the US. IDT's price from anywhere in the world to any city in the US is \$US 0.10 a minute, to other countries a destination dependant charge is added to this \$US 0.10 (e.g. from France to Australia is \$US 0.10 + \$US 0.20 = \$US 0.30 per minute).

The following conclusions from the tariff comparison in Table 2 can be drawn. Given the fact that the call-back and Internet telephony calls are routed via the US, they turn out to be the least expensive ones for calls from France to the US. Internet telephony is by far the cheapest. France Telecom lowered their international call rates several times during the past year. The most recent price decrease (March 1997) is included in this example. France Telecoms off-peak rate to the US is now competitive with call back and certainly the lowest for calls to neighbouring countries such as Belgium. IDT's Internet telephony seems hardly competitive for calls between European countries because the calls are routed via the US. A call from France to Australia is by far the cheapest if set up over the Internet and is even less expensive than to call Belgium over the PSTN. The costs of a 3 minute call within France via IDT's Internet telephony or AT&T's call-back are higher than over the PSTN.

Table 2. **Example of tariff differences using commercial Internet telephony, call back and PSTN service (off peak and peak rate from France Telecom (FT in this table), in three international and one national case. Prices are given in US\$ for a 3 minute call.**

From - To	Internet tel. (IDT)	Call back (AT&T)	PSTN off-peak (FT, VAT incl)	PSTN peak (FT, VAT incl)
France - France	1.05	2.25	0.39	0.74
France - Belgium	1.11	2.82	1.05	1.31
France - US	0.30	1.23	1.25	1.58
France - Australia	0.90	1.98	2.77	3.48

Note: Tariffs all from March 1997; 1US\$ = 5.64 FF (1 March 1997)

Source: OECD

However, three considerations have to be made. First the monthly subscription fee and initial charges are not included. It is unknown how much the subscription fee for Internet telephony will be, if any, but if this is low, Internet telephony may play a role even for long distance national calls and international, non-intercontinental calls. Second, neither the quality of the services nor availability is taken into account. At the moment the PSTN services are the easiest to use and offer the best quality. Third, France Telecom tariffs include 20.6 per cent VAT, the two other services do not include VAT. The VAT issue is discussed below.

VAT issues

One issue that requires review by governments is taxation of communication services over the Internet. This VAT issue is not a specific problem to Internet telephony, it has for instance already arisen in relation to call-back services. Some countries charge VAT on communication services, others do not and from there Internet telephony may be offered at lower consumer prices. As a result, companies based in such countries may have a competitive advantage over those that levy VAT, as Figure 6 illustrates on the basis of the examples given above. It shows that if VAT is excluded, the three-minute France Telecom off-peak call to Belgium is less expensive than via Internet and the call to the United States is less expensive than via call-back.

Figure 5. **Example of tariff differences using Internet telephony, call back and PSTN service (off peak and peak rate from France Telecom (FT)), in three international and one national case**

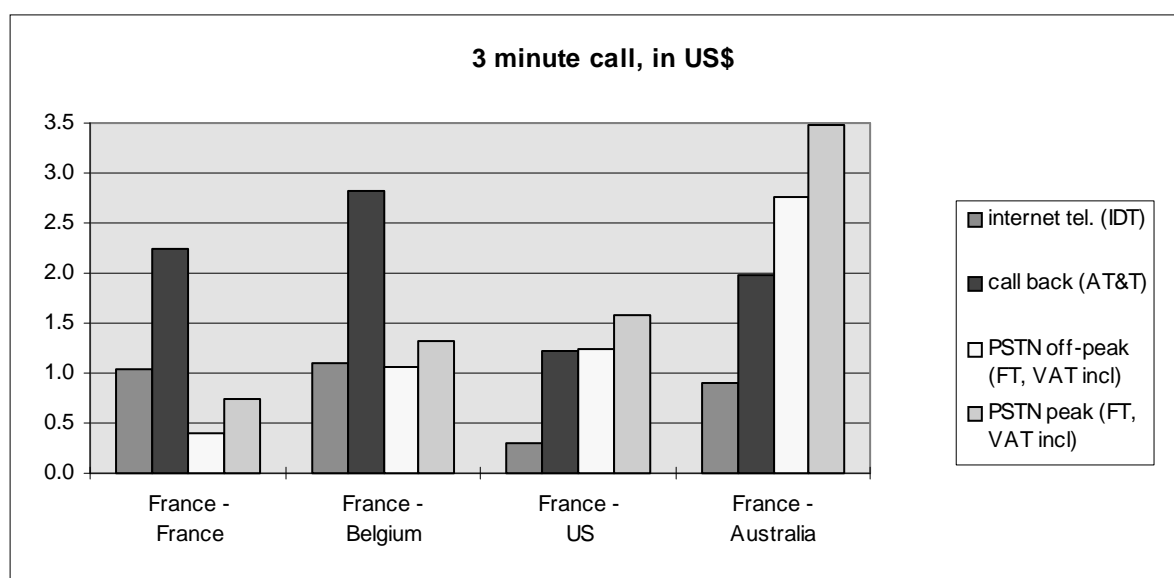

Source: OECD

The European Commission has proposed that foreign firms charge VAT on telecommunication services offered to EU customers, by January 1999, in response to growing use of call-back¹⁵. It also proposed interim rules to collect VAT on call-back. The call-back service market is estimated to be worth US\$ 500 million in 1996 and is forecast to reach US\$ 1 billion in 1997. It is unclear whether this will also effect Internet voice telephony which can be provided from outside the EU.

Financial experts in OECD state that there is concern about the enforceability of existing law and administrative measures as applied to cyberspace, for instance if an Internet entity cannot be precisely located for the purposes of taxation.

Figure 6. Extension of the example shown in Figure 5, to show the impact of VAT on the tariff of the various services; VAT applies only to the tariffs from France Telecom (FT).

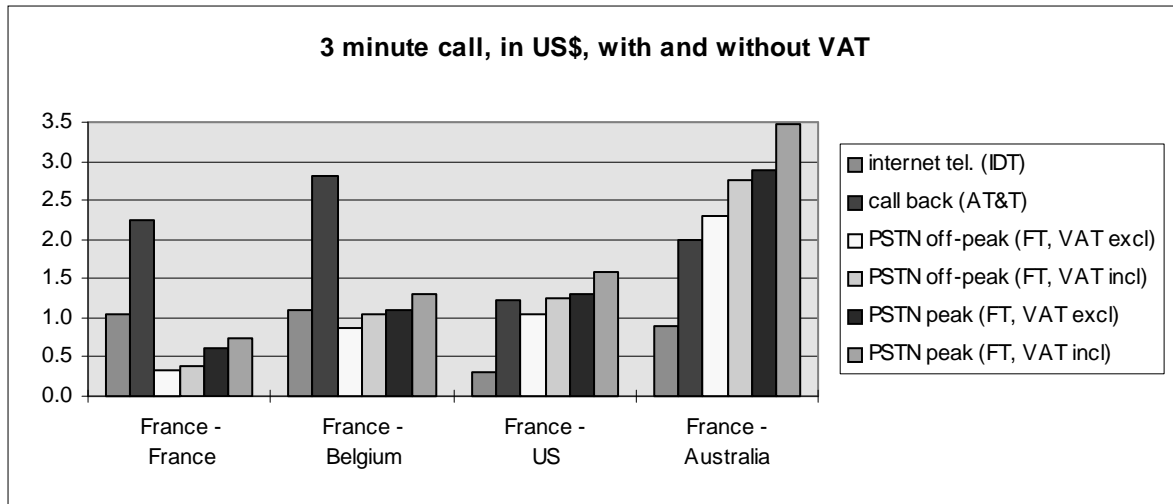

Source: OECD

5. MARKET AND POLICY ASPECTS

Market players

Telephony over the Internet has been introduced by a number of software companies, who are new entrants in the world of telecommunication services. ISPs are also starting to play a role in the provision of telephony services. The growth of Internet communication services stimulates the developers and manufacturers of Internet software and hardware and will also influence telecommunication equipment manufacturers. Other parties that play an important role related to Internet telephony are user and business groups, for example the Voice On the Net coalition (VON)¹⁶. It is an indication of growing importance of Internet telephony that the bigger players such as Microsoft (NetMeeting), Netscape (Cooltalk), Intel, IBM and PTOs like Telecom Finland are interested in this service and network combination. In 1996 the market was led by smaller players such as Net2Phone (via ISP IDT), NetSpeak (WebPhone), VocalTec (Internet Phone) and Voxware (Voxware codecs).

The impact on PTOs is twofold. On the one hand PTOs get more competition on their most important service via different networks. On the other hand PTOs can also provide Internet telephony and can profit from growth in traffic and in demand for more and higher speed network connections. One example of a PTO that has already started offering Internet telephony is Telecom Finland. In December 1996 it started with TF-MediaNet phone, jointly developed by Telecom Finland and VocalTec Inc.. Due to its ATM network Telecom Finland can guarantee the quality of the connections in Finland. This business differs from the traditional telecommunication operator role: Internet telephone technology enables several new value-added services and the initiative is therefore taken to stimulate the development of new applications. Other examples of companies offering Internet telephony are Net2Phone, via the Internet access provider IDT¹⁷, and OzEmail of Australia. Both recently announced they will offer an Internet telephony service to be used from existing tone-dial telephones¹⁸.

Market potential

Potential Internet telephony users are both residential and business users. Residential users are among the largest users of the service and profit from the big price difference on international calls. Although, at the moment many business users will not accept the present poor quality of Internet telephony, they are the ones that make most international calls and will therefore be attracted by the large price differences. Alternatives are high quality international calls via the PSTN and call-back services.

Estimates of the market potential of Internet telephony vary from the 23 million people that are on-line world-wide at the moment (Jupiter Communications, 1996), to the 170 million people that use a PC world-wide (ITU, 1995) to the total number of telephone users, being about 470 million in the OECD area (OECD 1995) and 700 million world-wide (ITU, 1995), see Table 3. The given numbers form an upper limit. The vast differences in the number of Internet hosts and the number of PC-users in OECD countries indicates that the availability and possibilities of Internet telephony also vary¹⁹. The highest

Internet hosts penetration and the highest PC household penetration can be found in countries with competition in services and infrastructure and in countries with flat rate or unmeasured local calls. Another important aspect of success for Internet telephony is the user interface, with the traditional telephone serving as the main reference to many potential customers.

Table 3. **Internet telephony market estimate**

Connection	Requirements	Market potential
computer to computer	Requires computers, equipped with audio features and similar telephony software.	Total number of PC-users, or total number of users on-line.
computer to telephone	Computer plus software for the sender; Internet telephony provider must have an interworking agreement with a destination network to have the call terminated on a telephone.	Total number of PC-users to set up a call; Total number of telephone users if they can be reached (interworking agreements required).
telephone to telephone	Any telephone user to any other; interworking required.	Total number of telephone users.

Source: OECD

Impact on the service market

Internet telephony bring an advantage for telecommunication users by its low price, although lower quality and network congestion may initially limit success. The lower prices also put pressure on the PSTN international tariffs. The costs of Internet telephony will increase because of the necessary investments in capacity, quality and improvements in service management, and consequently the prices will rise. Internet telephony may also lead to product differentiation in telephony, where different levels of quality-of-service and price co-exist. In the longer term the different underlying network technologies will co-exist and will be more transparent to users. Probably quality and costs will go up, so that Internet telephony will compete more on the enhanced service features than on price. It is clear that the service is stimulating network operators to evaluate the technological and related economic choices for all-service provision.

Impact on telephony revenues

What will be the impact of Internet telephony on the PTOs? It is assumed that Internet telephony competes with international calls because of the tariff difference. The revenues from international telephony compared with total revenues varies over the OECD countries between 3.5 per cent (Japan) and 45 per cent (Luxembourg); the average is 9.5 per cent. For smaller OECD countries the share of international calls in total revenues is much higher than for larger countries, but part of these international calls measure the same distance as national long distance calls in larger countries. It is uncertain how price competitive Internet telephony will be for this type of calls. The tariff example in Chapter 4 showed only a slight price difference between Internet telephony and PSTN for calls from France to Belgium, but the Internet telephony call was routed via the US. Probably the costs of an Internet call from France straight to

Belgium is less expensive. The impact of Internet telephony on international telephony revenues may be bigger in smaller countries, and particularly in countries where Internet usage and PC penetration are high, such as in the Scandinavian countries, New Zealand and Switzerland. Because of the differences in tariffs for local calls in the OECD countries, Internet telephony traffic will also vary. In countries with unmeasured or flat rate local calls, also Internet telephony will be cheaper.

Internet telephony could stimulate people to make more international calls, via Internet but also via the PSTN. It will stimulate tariff re-balancing and because of lower tariffs more international calls will be made. It is likely that total revenues from international calls will decrease because of the big price decreases. However lower revenues from international traffic may be compensated through higher revenues from Internet access services, from selling more network capacity to users such as ISDN and second lines, and from higher volumes of local Internet calls. Competition with long-distance / national calls may be attractive because of the big market volume, although the price will not be the main competitive advantage.

Impact on tariff structures

A fundamental difference exists in the tariff structure between Internet telephony and the telephony service from the PTOs. The providers of Internet telephony have a commercial advantage because they do not need to bill all the network costs. Namely the costs of the network where the call originates are billed by other players: the ISP for Internet access and the network operator for the local loop. Interconnection charges for the termination of Internet calls in the PSTN will be included in the service charge. PTOs with their own networks bill their customers an all-in tariff that includes both service charges and all direct and indirect network charges.

Pricing mechanisms for services over the Internet are under discussion among various parties. As bandwidth is scarce there is a need to control the use of it in order to guarantee certain levels of quality and availability. Pricing may depend on various parameters, such as the type of the service, the call duration, the time of the day, the amount of data transferred, or a combination of these parameters, for instance the data speed.

It is important to know whether daily traffic profiles of the use of the PSTN network will change because of Internet telephony. For Internet traffic in total, these profiles are different and show a traffic peak in the late afternoon and beginning of the evening, whereas telephony and fax services over the PSTN cause peak traffic during early business hours. But there are indications that the peak time for Internet is starting earlier and includes a whole working day plus evening²⁰. The usage profiles of the Internet telephony service, probably mainly used for international calls, may not be very much different. Business users will not change their usage so much. Residential users may change call habits, because the incentive to wait until off-peak for lower international PSTN call charges has gone. Of course these profiles vary among the countries due to differences in call charges, working hours and other cultural differences.

The average call duration of an Internet call is variously estimated to be four to seven times more than a telephone call²¹. In the UK the average call duration measured over all calls went up from five to seven minutes in four years, which may indicate longer Internet calls, but also indicates changed call habits due to lower tariffs and promotion campaigns. Growth in local calls is likely to increase due to Internet usage. An indication may be an analysis from the Financial Times, that showed that inland call volume in the UK has gone up from 5 per cent growth in 1995 to 7 per cent in 1996. Significantly about 10 per cent of BTs local call traffic in the latest quarter of 1996 is realised by on-line PC connections²².

Impact on level of accounting rates and total settlements

PTOs pay each other for terminating international calls on the PSTN, the so-called settlement fee. With Internet telephony the payment is different as the sender (the ISP) keeps all revenues and no settlement payments are made (the terminating ISP gets no compensation for the costs of terminating a call). Internet telephony will therefore impact on the level of accounting rates and the settlement payment because of the following reasons: 1) competitive pressure from international Internet telephony will tend to push accounting rates downwards; 2) Internet telephony could reduce the number of calls using the PSTN and therefore impact total settlements; 3) Internet telephony as one of the driving forces to lower the tariffs for international calls may stimulate the number of international calls which can to some extent compensate for lower accounting rates.

Developing countries benefit particularly from high accounting rates and for some of those countries income from settlement payments represents a significant source of foreign exchange. Internet telephony may therefore be feared in these countries, but in the longer term it is evident that a competitive and efficient telecommunication industry will stimulate economic growth. Other countries have net payments, such as the US that has a net settlements payment of \$ 4.9 billion in 1995²³. Internet telephony can help those countries to lower their net payment of accounting rates²⁴.

Examples of changes in international payments

An example to illustrate the change in tariff structures caused by Internet and its impact on settlements, is the comments from Telstra on the FCC Notice of Proposed Rulemaking (NPRM)²⁵. This example is on all Internet traffic, not particularly on Internet telephony. Telstra in its response to the FCC claims that non-US carriers around the world subsidise US Internet providers, because of the present arrangements for provision of international capacity to carry Internet traffic. The company says they still pay for 100 per cent of the cost of the international link because in the past almost all Internet traffic was from the US to Australia. Today, the pattern of traffic flow has significantly changed, estimated by Telstra in the order of 70:30 US-to-Australia vs. Australia-to-US. But US carriers still insist on Telstra paying for the cost of both half-circuits. (In the case of Telstra alone, this subsidy to the US in respect of the 82 Mbps capacity currently in place for Internet traffic (equivalent to 5 000 voice channels), presently amounts to approximately US \$ 9.6 million per annum).

Another interesting issue brought up in the comments from Telstra filed with the FCC is the level of US carrier outbound settlements and the Inbound/outbound ratio. The FCC states that the outward imbalance in the US i/o ratio has further widened, despite continuing reductions in the settlement rates with many countries, however Telstra comments that the NPRM does not pay very much attention to the fact that services such as Home Country Direct, use of telecommunications cards, call-back and refile traffic all generate traffic for US carriers and lead to outbound settlement to foreign carriers. But these services are generally in use by customers outside the US so payment of the bills is inbound to the US. For Internet telephony, also provided by most US companies, this will probably lead to net customer payments to the US, but also to lower outbound settlement payments if Internet telephony replaces international calls on the PSTN.

Applicability of telecommunication legislation

Telecommunication laws generally specify the conditions for provision of voice services to the public. Some countries believe that in order to have regulatory neutrality the same rules should apply to Internet voice telephony services. Other countries believe that applying the same rules would impede the development of innovative services. A service like Internet voice telephony could facilitate the transition to a competitive regime by offering an alternative technology to existing networks. Operators should be free to choose the underlying technology, not least because it is they who must invest in the various technologies. Moreover, when regulations do not impose the choice of technology, the situation is more favourable to new entrants and innovation in the communication market.

That it can be unclear from telecommunication acts and directives whether Internet telephony is treated as a public voice service and consequently has to fulfil these rules, is shown in the following two examples, one about the European Directive and the other about the ACTA petition in the US. They show that legislation still includes certain choices of technologies, normally based on technologies commonly used at the time of defining legislation and this may limit the investments made in the communication sector.

The European Directive 90/388/EEC on telecommunication services defines voice telephony, as: *'the commercial provision for the public of the direct transport and switching of speech in real-time between public switched network termination points, enabling any user to use equipment connected to such a network termination point in order to communicate with another termination point'*. As voice telephony can be provided over IP and will be allowed in a number of OECD countries, the question comes up whether voice over IP fits the definition. Important elements of this definition of voice telephony are: "commercial provisioning for the public", "direct transport and switching of speech in real-time between public switched network points", and "any user to use equipment to communicate with another termination point".

- Is provision of free Internet telephony a commercial provision of service? It can be realised in combination with watching or listening to advertisements.
- How important is real-time? Is a delay of less than one second acceptable as real-time? A journalist may send a recorded voice report to a publisher as a one-way voice message over the Internet. If it is sent as a store-and-forward message and arrives within seconds, it may be real-time but is a message service. If real-time is important in a voice telephony definition, it should be related to 'normal talk between humans' and perceived by users as interactive.
- Is it necessary for speech to be switched? In the PSTN the circuits are switched, in the packet-switched network the packets are switched. In other topologies that are becoming more popular for telecommunication networks, such as tree and bus structures, data are not switched but distributed to all connections and filtered out at the right one. The switching function allows for selection of one or more communication partners, which is not exclusively related to voice communication.
- Internet telephony is not yet universally available. However, calls can now be completed to any telephone in the world and there are no fundamental obstacles to offering the service to anyone, from a classic telephone terminal.

In the US, Internet telephony providers claim to be companies just selling software to avoid being treated as telecommunication carriers. But is there a fundamental difference between a call set-up via software installed on the PC or via a dedicated terminal (hardware and software) that is called a telephone? In March 1996 a group of relatively small telecommunication companies in the US, America's Carriers Telecommunications Association (ACTA), filed a petition to the FCC. The petition asks to limit Internet telephony via restricting the sale of Internet telephony software, because the providers of that software do not comply with the rules that apply to telecommunications²⁶. Internet telephony software developers and the VON ask the FCC to dismiss the petition.

The petition raises a question whether providers of Internet telephone software act as telecommunication carriers or telecommunication service providers. ACTA submits that the providers of this software are telecommunications carriers and, as such, should be subject to FCC regulation like all telecommunications carriers. The Internet telephony software providers prefer to be software sellers and not telecommunication service providers. One example is Clarity Software Inc., providing software for a fax service over the Internet, claims explicitly on their home site to be a software developer and not a phone company.

6. POLICY CONSEQUENCES

Voice services over packet switched networks, such as Internet telephony and related video services illustrate the convergence in telecommunication. The liberalisation of the telecommunication market opens the possibilities to combine existing service and network technologies where Internet telephony is an example of the integration of computer business and telecommunication business. The use of alternative infrastructures brings also new service features.

Moreover it is the technological development that stimulates this integration and places pressure for faster change in regulations. The use of alternative network infrastructures and the fact that often new companies start with exploring the new possibilities stimulates competition in the communication market, which is in line with existing liberalisation policies.

Developments in compression techniques will lead to transport possibilities of high quality speech and video over data networks. In principle all communication networks can be used for all communication services, but some combinations of service and network lead to a better price-quality combination or in some cases a service network combination is necessary to achieve a certain high level of quality, availability or security.

To most customers the question of which network is used is irrelevant. A customer asks for a certain service, with price/quality as a condition. Implicitly the service request contains speed and possibly network requirements, which are to be met by service and network providers.

Service providers without a network prefer to rent low cost network capacity that meets their service requirements in terms of quality and availability. Network providers have the same requirements for their own service provision, but have also to meet the demands from other service providers renting capacity (wholesale). Based on these two types of demand, network operators invest in upgrading and new network technologies and decide on the physical medium and topology, the logical network architecture and the protocols for data transportation.

Regulation should therefore be independent from the service/network combination, in order to allow growth in the communication market through exploiting new service/network combinations, which often are initiated by players who are new entrants in the communication market. It also enhances the diversity of service supply.

GLOSSARY

ACTA	America's Carriers Telecommunications Association
ADSL	Asymmetric Digital Subscriber Loop
ATM	Asynchronous Transfer Mode
IETF	Internet Engineering Task Force
IMA	International Multimedia Association
IMTC	International Multimedia Teleconferencing Consortium

